

HANDBOOK  
**EXPANSION VALVES**

---

Ed. 2017

 **Castel**<sup>®</sup>  
Italian technology

# CHAPTER 3 ■ SOLENOID EXPANSION VALVES

## FOR REFRIGERATION PLANTS THAT USE HCFC OR HFC REFRIGERANTS, HFO



### APPLICATIONS

The solenoid expansion valves in series 2028 illustrated in this chapter can be used in a wide range of applications as listed below:

- Refrigeration systems (display cases in supermarkets, freezers, ice cream and icemaker machines, refrigerated shipping, etc.).
- Air conditioning systems
- Heat pump systems
- Liquid chillers

That use the following refrigerant fluids:

- HCFC (R22)
- HFC (R134a, R404A, R407C, R410A, or R507)
- HFO and HFO/HFC mixtures (R1234ze, R448A, R449A, R450A, and R452A)

belonging to Group 2, as defined in Article 13, Chapter 1(b) of Directive 2014/68/EU, with reference to EC Regulation No. 1272/2008.

The same solenoid valves can also be installed on systems that use the following refrigeration fluids:

- HFC (R32)
- HFO (R1234yf)

classified as A2L in the ASHRAE 34-2013 standard, and belonging to Group 1, as defined in Article 13, Chapter 1, Point (a) of Directive 2014/68/EU, with reference to EC Regulation No. 1272/2008.

For specific applications with refrigerant fluids not listed above, please contact Castel Technical Department.

### OPERATION

The valve in series 2028 is a throttling device that receives liquid from the condenser and injects it into the evaporator, creating the necessary pressure drop across the expansion orifice. It regulates the refrigerant flow into the evaporator by modulating the opening time phase of the shutter, allowing for a wide power range. It is an ON/OFF valve that must be regulated with the **Pulse Width Modulation (PWM)** principle and it can be actuated by a very simple electronic controller. According to the PWM principle, the evaporator refrigerant flow rate,  $Q_T$ , required in a fixed period "T", is delivered by the valve in a time interval "t", shorter than "T", during which the maximum flow rate is allowed (ON step). In time period that remains,  $T - t$ , the valve stays closed (OFF phase).

For an effective regulation, the PWM valve must be sized in such a way that, under the most severe operating load conditions, the orifice of the valve is large enough to deliver the refrigerant required. In these extreme conditions, the valve will stay open for the entire period "T".

The use of an electronic regulator allows a more accurate metering of the refrigerant, obtaining a greater efficiency in time (and a sensible decrease in machinery management costs) and a faster response to the variations of the evaporator load.

### CONSTRUCTION

The valves in series 2028 are supplied complete with orifice. Nine different orifices with nine different maximum capacities that range from orifice 01 to orifice 09 can be assembled. The last two numbers in the part number identify the type of orifice that has been mounted on the valve at the factory. For example, part number 2028/3S02 identifies a 3/8" valve with solder connections and size 02 orifice. The orifices are interchangeable and can be mounted even after the valve is soldered on the system. If you wish to change orifice, purchase the corresponding spare parts kit, according to the part number indicated in Table 14. Inside the valve body is a ring mesh filter that traps dirt and contaminants at the valve inlet.

Valves in series 2028 are sold exclusively in the model without coil (suffix S).

The main parts of the valves in series 2028 are manufactured with the following materials:

- Hot forged brass EN 12420 – CW617N for the body
- Hot forged brass EN 12420 – CW724R for mobile plunger valve sleeve

- Ferritic stainless steel EN 10088-3 – 1.4105 for the fixed and mobile plungers
- Austenitic stainless steel EN 10088-3 – 1.4301 for the mesh filter
- Austenitic stainless steel EN 10088-3 – 1.4305 for orifice
- Copper pipe EN 12735-1 – Cu--DHP for solder connections
- P.T.F.E. for seat gaskets
- Chloroprene rubber (CR) for outlet seal gaskets

## SELECTION

To dimension a valve in series 2028 for a refrigerating system correctly, the following design parameters must be available:

- Type of refrigerant
- Evaporator capacity,  $Q_e$
- Evaporating temperature/pressure,  $T_e / p_e$
- Minimum condensing temperature/pressure,  $T_c / p_c$
- Liquid refrigerant temperature at valve inlet,  $T_l$
- Pressure drop in the liquid line, distributor and evaporator,  $\Delta p$

The following procedure helps the correct dimensioning of an expansion valve for a refrigeration plant.

### Step 1

*Determine the pressure drop across the valve.* The pressure drop is calculated using the equation:

$$\Delta p_{\text{tot}} = p_c - (p_e + \Delta p)$$

where:

- $p_c$  = condensing pressure
- $p_e$  = evaporating pressure
- $\Delta p$  = sum of pressure drops in the liquid line, distributor and evaporator at the maximum flow rate, that is with the valve always open

### Step 2

*Evaporator capacity correction with subcooling.* The evaporator capacity,  $Q_e$ , must be suitably sized based on the subcooling value. The subcooling is calculated using the equation:

$$\Delta T_{\text{sub}} = T_c - T_l$$

In the subcooling correction factor table, find the appropriate correction factor,  $F_{\text{sub}}$ , corresponding to the calculated  $\Delta T_{\text{sub}}$  value and determine the required valve capacity using the equation:

$$Q_{\text{sub}} = \frac{Q_e}{F_{\text{sub}}}$$

### Step 3

*Capacity correction based on the application.* To obtain a correct regulation with this valve, it is necessary it be oversized so that its closing period is 25% to 50% of the regulator's total period,  $T$ . The correct choice of this potential margin depends on the application, which can have variable flow rate peaks, and on the control algorithm used by the electronic control unit.

Generally, however, this correction factor,  $F_{\text{ev}}$ , is highly dependent by the evaporation temperature,  $T_e$ , so it be assumed equal to 125% for  $T_e \geq -15$  °C and 150% for  $T_e < -15$  °C. These generic values must be verified based on the specific application.

The capacity of the valve must be at least equal to:

$$Q_{\text{ev}} = F_{\text{ev}} \cdot Q_{\text{sub}}$$

### Step 4

*Determine required orifice size.* Use the pressure drop across the valve, the evaporating temperature and the correct evaporator capacity,  $Q_e$ , calculated above, to select the corresponding orifice size from the capacity table corresponding to the chosen refrigerant fluid.

### Step 5

*Liquid line sizing.* Since the valve operates under ON/OFF criteria, during the opening phase, the flow rate can be much higher than the average flow rate in the time period. For this reason, the designer must size the diameter of the pipes of the liquid line according to the maximum flow rate across the orifice in the real conditions of  $\Delta p_{\text{tot}}$  and to avoid that a drop-in load cause a reduction in the maximum valve power.

## DIMENSIONING EXAMPLE

- Type of refrigerant: R404A
- Evaporator capacity,  $Q_e$ : 2.8 kW
- Evaporating temperature,  $T_e$ : - 10°C
- Minimum condensing temperature,  $T_c$ : +35°C
- Liquid refrigerant temperature,  $T_l$ : +20°C
- Pressure drop in the liquid line, distributor and evaporator,  $\Delta p$  2 bar

*Step 1 - Determine the pressure drop across the valve.*

- Condensing pressure at + 35 °C -  $p_c = 16.9$  bar
- Evaporating pressure at - 10 °C -  $p_e = 4.4$  bar

$$\Delta p_{\text{tot}} = 16,9 - (4,4 + 2) = 10,5 \cdot \text{bar}$$

*Step 2 - Determine required valve capacity*

$$\Delta T_{\text{sub}} = 35 - 20 = 15 \cdot \text{°K}$$

From the subcooling correction factor Table 18B, we find the appropriate correction factor,  $F_{\text{sub}}$ , equal to 1.17 for  $\Delta T_{\text{sub}} = 15$  °K. The required valve capacity is

$$Q_{\text{sub}} = \frac{2,8}{1,17} = 2,39 \cdot \text{kW}$$

*Step 3 - Capacity correction based on the application*

According to the above criterion, a correction of + 25% is applied to the calculated capacity:

$$Q_{\text{ev}} = 1,25 \cdot 2,39 = 3 \cdot \text{kW}$$

*Step 4 - Determine required orifice dimension.*

Using table for the capacity for refrigerant fluid R404A, enter the data:

- Pressure drop across the valve = 10.5 bar
- Evaporating temperature = - 10 °C
- Calculated evaporator capacity = 3 kW

Select the corresponding orifice, 04 (Note: the expansion valve capacity must be equal to or slightly greater than the calculated evaporator capacity).

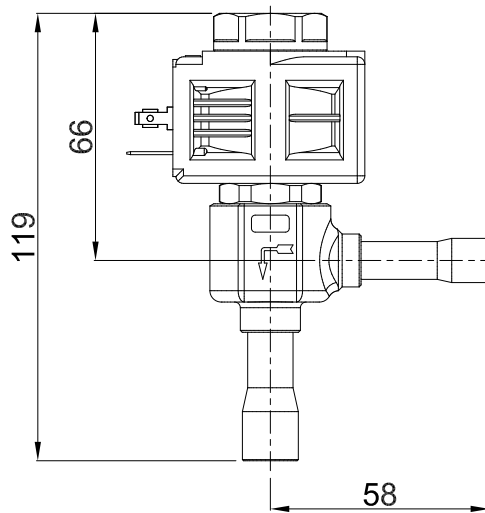

2028/3  
2028/M10

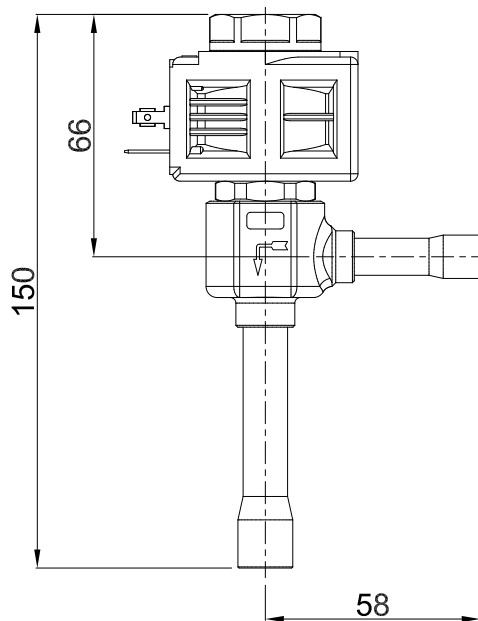

2028/4  
2028/M12

**TABLE 13: General characteristics of PWM expansion valves**

Catalogue number	Orifice Type	ODS Connections				Kv Factor [m³/h]	Opening Pressure Differential [bar]				Operating principles	Minimum Working Time [s]	PS [bar]	TS [°C]		TA [°C]		Risk Category according to PED Recast			
		[in]		[mm]			MinOPD	MOPD						min.	max.	min.	max.				
		IN	OUT	IN	OUT			9160 (AC)	9160 (DC)	9320 (AC)									9320 (DC)		
2028/3S01	01	3/8"	1/2"	-	-	0				PWM (Pulse Width Modulating)	1	45	-40	+100	-40	+50	Art.4.3				
2028/M10S01		-	-	10	12																
2028/3S02	02	3/8"	1/2"	-	-													37	37	37	37
2028/M10S02		-	-	10	12																
2028/3S03	03	3/8"	1/2"	-	-													37	37	37	37
2028/M10S03		-	-	10	12																
2028/3S04	04	3/8"	1/2"	-	-													37	37	37	37
2028/M10S04		-	-	10	12																
2028/3S05	05	3/8"	1/2"	-	-													37	37	37	37
2028/M10S05		-	-	10	12																
2028/3S06	06	3/8"	1/2"	-	-													27	18	14	27
2028/M10S06		-	-	10	12																
2028/4S07	07	1/2"	5/8"	-	-													18	14	32	32
2028/M12S07		-	-	12	16																
2028/4S08	08	1/2"	5/8"	-	-													18	14	27	27
2028/M12S08		-	-	12	16																
2028/4S09	09	1/2"	5/8"	-	-													10	22	22	22
2028/M12S09		-	-	12	16																

**TABLE 14: Orifices - Rated capacities in kW**

Catalogue number	Orifice Type	Orifice Size [mm]	Refrigerant												
			R134a	R22	R32	R404A	R407C	R410A	R507A	R1234yf	R1234ze	R448A	R449A	R450A	R452A
9150/R63	01	0,5	0,74	1,04	2,44	0,73	1,18	1,16	0,76	0,56	0,59	1,02	1,13	0,63	0,90
9150/R64	02	0,7	1,47	2,08	4,88	1,47	2,35	2,31	1,52	1,12	1,17	2,04	2,26	1,26	1,81
9150/R65	03	0,8	1,74	2,46	5,74	1,73	2,77	2,72	1,79	1,32	1,39	2,40	2,66	1,49	2,13
9150/R66	04	1,1	2,81	3,99	9,34	2,81	4,50	4,42	2,91	2,13	2,24	3,90	4,32	2,40	3,46
9150/R67	05	1,3	4,81	6,81	15,91	4,78	7,68	7,54	4,96	3,65	3,84	6,64	7,37	4,11	5,90
9150/R68	06	1,7	6,67	9,44	22,06	6,63	10,65	10,45	6,88	5,06	5,33	9,21	10,22	5,71	8,19
9150/R69	07	2,3	10,52	14,92	34,94	10,49	16,83	16,54	10,88	7,98	8,39	14,57	16,15	8,98	12,95
9150/R78	08	2,5	12,68	17,96	42,00	12,62	20,26	19,89	13,09	9,62	10,12	17,53	19,44	10,84	15,58
9150/R79	09	2,7	14,07	19,91	46,54	13,99	22,46	22,05	14,51	10,67	11,23	19,43	21,55	12,03	17,27

Rated capacities are based on:

- Evaporating temperature  $T_{\text{evap}} = + 5 \text{ °C}$
- Condensing temperature  $T_{\text{cond}} = + 32 \text{ °C}$
- Refrigerant liquid temperature ahead of valve  $T_{\text{liq}} = + 28 \text{ °C}$

**TABLE 15A: Refrigerant R134a - Capacities in kW**

Evaporating Temperature 10 °C										Evaporating Temperature 0 °C									
Orifice Type	Pressure drop across valve [bar]									Orifice Type	Pressure drop across valve [bar]								
	2	4	6	8	10	12	14	16	18		2	4	6	8	10	12	14	16	18
01	0,62	0,73	0,82	0,90	0,96	1,01	1,04	1,06	1,07	01	0,63	0,74	0,83	0,90	0,96	1,00	1,03	1,05	1,05
02	1,23	1,46	1,65	1,80	1,92	2,01	2,08	2,12	2,13	02	1,26	1,48	1,66	1,81	1,92	2,00	2,06	2,09	2,10
03	1,46	1,72	1,94	2,12	2,26	2,37	2,44	2,49	2,50	03	1,50	1,75	1,96	2,13	2,26	2,35	2,42	2,46	2,46
04	2,35	2,79	3,15	3,45	3,68	3,86	3,99	4,06	4,08	04	2,42	2,84	3,18	3,46	3,68	3,84	3,95	4,01	4,02
05	4,03	4,77	5,38	5,87	6,27	6,57	6,78	6,90	6,95	05	4,14	4,85	5,43	5,90	6,26	6,53	6,72	6,82	6,83
06	5,60	6,62	7,46	8,15	8,69	9,10	9,40	9,56	9,63	06	5,75	6,73	7,53	8,18	8,68	9,06	9,32	9,45	9,47
07	8,80	10,43	11,78	12,88	13,76	14,42	14,90	15,17	15,27	07	9,04	10,61	11,90	12,94	13,75	14,35	14,77	14,99	15,02
08	10,63	12,58	14,18	15,50	16,54	17,33	17,90	18,22	18,34	08	10,92	12,79	14,33	15,56	16,53	17,24	17,75	18,00	18,03
09	11,80	13,95	15,73	17,18	18,33	19,20	19,83	20,18	20,31	09	12,13	14,19	15,89	17,25	18,32	19,11	19,66	19,94	19,98
Evaporating Temperature -10 °C										Evaporating Temperature -20 °C									
Orifice Type	Pressure drop across valve [bar]									Orifice Type	Pressure drop across valve [bar]								
	2	4	6	8	10	12	14	16	18		2	4	6	8	10	12	14	16	18
01	0,64	0,75	0,83	0,90	0,95	0,99	1,01	1,02	1,02	01	0,65	0,75	0,82	0,88	0,93	0,96	0,98	0,98	0,99
02	1,29	1,49	1,66	1,80	1,90	1,97	2,02	2,04	2,03	02	1,30	1,49	1,65	1,77	1,86	1,92	1,96	1,96	1,97
03	1,53	1,77	1,96	2,11	2,23	2,32	2,37	2,39	2,39	03	1,55	1,76	1,94	2,08	2,19	2,26	2,30	2,30	2,32
04	2,46	2,86	3,18	3,44	3,63	3,78	3,87	3,90	3,90	04	2,49	2,85	3,15	3,38	3,56	3,68	3,75	3,76	3,78
05	4,22	4,88	5,43	5,86	6,19	6,43	6,58	6,64	6,63	05	4,27	4,88	5,38	5,77	6,06	6,27	6,37	6,40	6,43
06	5,86	6,77	7,53	8,13	8,58	8,91	9,12	9,21	9,19	06	5,93	6,77	7,46	8,00	8,41	8,69	8,83	8,87	8,92
07	9,20	10,68	11,89	12,85	13,58	14,12	14,45	14,60	14,57	07	9,31	10,67	11,78	12,65	13,31	13,76	14,00	14,07	14,14
08	11,12	12,87	14,32	15,46	16,33	16,97	17,36	17,53	17,50	08	11,25	12,86	14,18	15,22	16,00	16,54	16,82	16,89	16,98
09	12,34	14,28	15,87	17,14	18,10	18,80	19,24	19,42	19,38	09	12,49	14,27	15,73	16,88	17,73	18,33	18,64	18,71	18,81
Evaporating Temperature -30 °C										Evaporating Temperature -40 °C									
Orifice Type	Pressure drop across valve [bar]									Orifice Type	Pressure drop across valve [bar]								
	2	4	6	8	10	12	14	16	18		2	4	6	8	10	12	14	16	18
01	0,65	0,74	0,81	0,86	0,90	0,93	0,94	0,93	0,92	01	0,64	0,72	0,78	0,82	0,86	0,87	0,88	0,87	0,85
02	1,30	1,48	1,61	1,72	1,80	1,85	1,87	1,87	1,84	02	1,28	1,43	1,56	1,65	1,71	1,75	1,76	1,74	1,69
03	1,55	1,75	1,90	2,03	2,12	2,17	2,20	2,19	2,16	03	1,52	1,69	1,83	1,94	2,01	2,05	2,06	2,04	1,99
04	2,49	2,82	3,09	3,30	3,45	3,54	3,59	3,58	3,52	04	2,44	2,74	2,98	3,15	3,28	3,35	3,36	3,33	3,25
05	4,27	4,82	5,27	5,62	5,87	6,03	6,10	6,09	5,99	05	4,18	4,68	5,08	5,38	5,59	5,70	5,72	5,66	5,52
06	5,94	6,70	7,31	7,80	8,14	8,36	8,46	8,44	8,30	06	5,81	6,49	7,05	7,46	7,75	7,90	7,93	7,84	7,65
07	9,33	10,56	11,55	12,34	12,89	13,25	13,41	13,39	13,17	07	9,13	10,24	11,13	11,79	12,26	12,52	12,58	12,43	12,14
08	11,27	12,73	13,91	14,84	15,50	15,92	16,11	16,08	15,81	08	11,03	12,34	13,40	14,19	14,74	15,04	15,11	14,93	14,57
09	12,51	14,12	15,42	16,45	17,18	17,64	17,85	17,82	17,52	09	12,24	13,69	14,86	15,73	16,34	16,67	16,74	16,54	16,14

**TABLE: 15B - Correction factors for subcooling  $\Delta t_{sub} \neq 4^\circ K$**

$\Delta t_{sub} [^\circ K]$	4	10	15	20	25	30	35	40	45
$F_{sub}$	1,00	1,06	1,12	1,17	1,23	1,29	1,35	1,44	1,49

When subcooling ahead of the expansion valve is other than 4 °K , adjust the evaporator capacity by dividing by the appropriate correction factor found in Table 15B

**TABLE 16A: Refrigerant R22 - Capacities in kW**

Evaporating Temperature 10 °C										Evaporating Temperature 0 °C									
Orifice Type	Pressure drop across valve [bar]									Orifice Type	Pressure drop across valve [bar]								
	2	4	6	8	10	12	14	16	18		2	4	6	8	10	12	14	16	18
01	0,68	0,84	0,97	1,08	1,18	1,27	1,34	1,39	1,44	01	0,72	0,87	1,00	1,12	1,22	1,30	1,37	1,43	1,47
02	1,37	1,67	1,93	2,16	2,36	2,53	2,68	2,79	2,87	02	1,43	1,74	2,00	2,24	2,43	2,60	2,74	2,85	2,94
03	1,62	1,98	2,28	2,55	2,78	2,98	3,14	3,27	3,37	03	1,70	2,06	2,36	2,63	2,86	3,06	3,22	3,35	3,45
04	2,62	3,20	3,70	4,14	4,53	4,85	5,12	5,34	5,51	04	2,74	3,33	3,84	4,28	4,66	4,98	5,25	5,47	5,63
05	4,48	5,46	6,32	7,06	7,71	8,26	8,72	9,09	9,36	05	4,70	5,69	6,55	7,29	7,93	8,48	8,94	9,30	9,58
06	6,22	7,58	8,77	9,80	10,69	11,45	12,09	12,59	12,98	06	6,52	7,89	9,08	10,12	11,00	11,76	12,39	12,89	13,28
07	9,78	11,95	13,85	15,49	16,92	18,14	19,16	19,97	20,59	07	10,25	12,44	14,34	16,00	17,41	18,63	19,64	20,44	21,06
08	11,82	14,40	16,67	18,64	20,35	21,80	23,02	23,99	24,72	08	12,38	15,00	17,27	19,25	20,93	22,39	23,59	24,55	25,29
09	13,12	15,98	18,49	20,66	22,55	24,15	25,50	26,57	27,38	09	13,75	16,64	19,15	21,34	23,20	24,81	26,14	27,20	28,02
Evaporating Temperature -10 °C										Evaporating Temperature -20 °C									
Orifice Type	Pressure drop across valve [bar]									Orifice Type	Pressure drop across valve [bar]								
	2	4	6	8	10	12	14	16	18		2	4	6	8	10	12	14	16	18
01	0,74	0,90	1,03	1,14	1,24	1,32	1,38	1,44	1,48	01	0,77	0,92	1,04	1,15	1,24	1,32	1,39	1,44	1,47
02	1,49	1,79	2,05	2,28	2,47	2,63	2,77	2,88	2,96	02	1,54	1,83	2,08	2,30	2,49	2,64	2,77	2,87	2,95
03	1,77	2,12	2,42	2,68	2,91	3,10	3,25	3,38	3,47	03	1,82	2,16	2,46	2,71	2,93	3,11	3,26	3,37	3,46
04	2,85	3,43	3,93	4,36	4,73	5,05	5,30	5,52	5,67	04	2,94	3,50	3,99	4,41	4,77	5,06	5,31	5,50	5,64
05	4,87	5,85	6,70	7,43	8,06	8,59	9,03	9,38	9,64	05	5,03	5,98	6,81	7,51	8,12	8,62	9,03	9,35	9,60
06	6,77	8,12	9,29	10,31	11,18	11,91	12,51	13,00	13,36	06	6,99	8,31	9,44	10,42	11,26	11,95	12,52	12,97	13,31
07	10,64	12,81	14,68	16,30	17,69	18,87	19,83	20,62	21,19	07	10,99	13,09	14,91	16,48	17,82	18,93	19,85	20,56	21,11
08	12,85	15,44	17,68	19,61	21,27	22,67	23,83	24,77	25,45	08	13,27	15,79	17,96	19,83	21,42	22,75	23,85	24,70	25,34
09	14,26	17,13	19,60	21,74	23,57	25,12	26,40	27,44	28,19	09	14,73	17,51	19,91	21,98	23,74	25,21	26,42	27,36	28,07
Evaporating Temperature -30 °C										Evaporating Temperature -40 °C									
Orifice Type	Pressure drop across valve [bar]									Orifice Type	Pressure drop across valve [bar]								
	2	4	6	8	10	12	14	16	18		2	4	6	8	10	12	14	16	18
01	0,78	0,92	1,04	1,15	1,23	1,31	1,37	1,41	1,44	01	0,80	0,93	1,04	1,14	1,22	1,29	1,34	1,38	1,41
02	1,56	1,84	2,09	2,29	2,47	2,62	2,73	2,82	2,89	02	1,59	1,86	2,09	2,28	2,45	2,58	2,69	2,77	2,82
03	1,85	2,18	2,46	2,70	2,90	3,07	3,21	3,31	3,39	03	1,89	2,19	2,46	2,69	2,88	3,03	3,16	3,25	3,31
04	2,99	3,53	3,99	4,39	4,73	5,01	5,23	5,40	5,53	04	3,04	3,55	3,99	4,37	4,68	4,94	5,15	5,30	5,40
05	5,11	6,03	6,81	7,48	8,05	8,52	8,90	9,19	9,40	05	5,21	6,07	6,81	7,44	7,98	8,41	8,76	9,01	9,19
06	7,10	8,36	9,45	10,38	11,17	11,82	12,33	12,74	13,03	06	7,24	8,42	9,45	10,32	11,06	11,66	12,14	12,50	12,73
07	11,16	13,19	14,92	16,41	17,68	18,72	19,55	20,21	20,67	07	11,37	13,28	14,92	16,33	17,51	18,47	19,25	19,81	20,20
08	13,49	15,90	17,97	19,74	21,25	22,50	23,49	24,27	24,82	08	13,74	16,01	17,97	19,64	21,05	22,20	23,12	23,80	24,25
09	14,97	17,63	19,92	21,88	23,55	24,93	26,02	26,89	27,50	09	15,25	17,75	19,92	21,77	23,33	24,60	25,62	26,36	26,87

**TABLE 16B - Correction factors for subcooling  $\Delta t_{sub} \neq 4^\circ K$**

$\Delta t_{sub} [^\circ K]$	4	10	15	20	25	30	35	40	45
Fsub	1,00	1,05	1,10	1,15	1,20	1,25	1,29	1,40	1,45

When subcooling ahead of the expansion valve is other than 4 °K , adjust the evaporator capacity by dividing by the appropriate correction factor found in Table 16B

**TABLE 17A: Refrigerant R32 - Capacities in kW**

Evaporating Temperature 10 °C										Evaporating Temperature 0 °C									
Orifice Type	Pressure drop across valve [bar]									Orifice Type	Pressure drop across valve [bar]								
	2	4	6	8	10	12	14	16	18		2	4	6	8	10	12	14	16	18
01	1,16	1,46	1,74	2,01	2,26	2,50	2,72	2,93	3,13	01	1,24	1,55	1,85	2,12	2,38	2,63	2,86	3,07	3,28
02	2,32	2,92	3,48	4,01	4,52	4,99	5,44	5,86	6,26	02	2,48	3,11	3,69	4,24	4,76	5,25	5,71	6,15	6,56
03	2,75	3,45	4,11	4,73	5,31	5,87	6,39	6,88	7,34	03	2,95	3,67	4,35	4,99	5,60	6,17	6,71	7,21	7,69
04	4,43	5,58	6,66	7,69	8,65	9,56	10,42	11,22	11,98	04	4,75	5,94	7,06	8,12	9,12	10,05	10,94	11,78	12,56
05	7,59	9,54	11,37	13,10	14,73	16,27	17,72	19,09	20,38	05	8,13	10,15	12,05	13,84	15,53	17,12	18,62	20,03	21,36
06	10,55	13,24	15,78	18,17	20,43	22,56	24,57	26,47	28,24	06	11,29	14,09	16,72	19,20	21,53	23,73	25,81	27,76	29,61
07	16,58	20,87	24,92	28,73	32,33	35,74	38,95	41,97	44,80	07	17,74	22,22	26,41	30,36	34,08	37,59	40,90	44,03	46,97
08	20,03	25,16	30,00	34,57	38,87	42,96	46,79	50,40	53,80	08	21,43	26,78	31,80	36,52	40,98	45,18	49,14	52,88	56,39
09	22,23	27,91	33,27	38,32	43,08	47,60	51,84	55,84	59,59	09	23,79	29,71	35,26	40,48	45,42	50,06	54,44	58,58	62,47
Evaporating Temperature -10 °C										Evaporating Temperature -20 °C									
Orifice Type	Pressure drop across valve [bar]									Orifice Type	Pressure drop across valve [bar]								
	2	4	6	8	10	12	14	16	18		2	4	6	8	10	12	14	16	18
01	1,26	1,58	1,87	2,15	2,41	2,66	2,89	3,10	3,31	01	1,30	1,62	1,91	2,19	2,45	2,70	2,93	3,15	3,35
02	2,53	3,16	3,74	4,30	4,82	5,31	5,77	6,21	6,62	02	2,61	3,24	3,83	4,38	4,91	5,40	5,86	6,30	6,71
03	3,00	3,73	4,42	5,06	5,67	6,24	6,78	7,29	7,77	03	3,10	3,83	4,52	5,16	5,77	6,34	6,88	7,39	7,87
04	4,83	6,04	7,17	8,23	9,23	10,17	11,06	11,89	12,69	04	4,99	6,20	7,33	8,39	9,39	10,33	11,22	12,06	12,85
05	8,28	10,32	12,23	14,02	15,72	17,31	18,82	20,23	21,57	05	8,55	10,59	12,51	14,30	16,00	17,59	19,10	20,52	21,85
06	11,50	14,32	16,97	19,45	21,79	24,00	26,09	28,04	29,90	06	11,87	14,70	17,35	19,84	22,18	24,39	26,47	28,44	30,28
07	18,08	22,57	26,79	30,76	34,50	38,02	41,35	44,47	47,43	07	18,66	23,18	27,41	31,38	35,12	38,64	41,96	45,09	48,04
08	21,84	27,21	32,26	37,01	41,48	45,69	49,68	53,41	56,95	08	22,54	27,94	33,00	37,75	42,22	46,43	50,41	54,16	57,68
09	24,24	30,19	35,77	41,02	45,97	50,63	55,04	59,17	63,09	09	25,02	30,99	36,59	41,85	46,79	51,45	55,85	60,00	63,89
Evaporating Temperature -30 °C										Evaporating Temperature -40 °C									
Orifice Type	Pressure drop across valve [bar]									Orifice Type	Pressure drop across valve [bar]								
	2	4	6	8	10	12	14	16	18		2	4	6	8	10	12	14	16	18
01	1,34	1,65	1,94	2,22	2,48	2,72	2,95	3,16	3,37	01	1,36	1,66	1,95	2,22	2,48	2,72	2,94	3,15	3,35
02	2,67	3,30	3,88	4,43	4,95	5,44	5,90	6,33	6,74	02	2,71	3,33	3,90	4,44	4,95	5,43	5,88	6,31	6,71
03	3,17	3,90	4,58	5,22	5,82	6,39	6,92	7,43	7,90	03	3,22	3,93	4,60	5,23	5,82	6,38	6,91	7,40	7,87
04	5,11	6,31	7,43	8,49	9,48	10,41	11,30	12,12	12,91	04	5,19	6,36	7,47	8,50	9,48	10,40	11,27	12,08	12,85
05	8,75	10,78	12,68	14,46	16,15	17,73	19,22	20,62	21,95	05	8,88	10,87	12,74	14,49	16,15	17,70	19,17	20,55	21,85
06	12,16	14,97	17,60	20,06	22,39	24,58	26,65	28,58	30,42	06	12,34	15,09	17,68	20,10	22,39	24,54	26,58	28,48	30,28
07	19,11	23,60	27,79	31,73	35,44	38,94	42,23	45,32	48,25	07	19,40	23,79	27,92	31,79	35,44	38,88	42,12	45,16	48,04
08	23,09	28,45	33,47	38,17	42,62	46,79	50,74	54,43	57,94	08	23,43	28,69	33,62	38,25	42,62	46,73	50,60	54,24	57,68
09	25,63	31,56	37,11	42,31	47,23	51,85	56,21	60,30	64,18	09	26,01	31,82	37,28	42,40	47,23	51,78	56,07	60,09	63,89

**TABLE: 17B - Correction factors for subcooling  $\Delta t_{sub} \neq 4^\circ K$**

$\Delta t_{sub} [^\circ K]$	4	10	15	20	25	30	35	40	45
$F_{sub}$	1,00	1,06	1,11	1,16	1,22	1,27	1,32	1,43	1,48

When subcooling ahead of the expansion valve is other than 4 °K , adjust the evaporator capacity by dividing by the appropriate correction factor found in Table 17B



**TABLE 18A: Refrigerant R404A - Capacities in kW**

Evaporating Temperature 10 °C										Evaporating Temperature 0 °C									
Orifice Type	Pressure drop across valve [bar]									Orifice Type	Pressure drop across valve [bar]								
	2	4	6	8	10	12	14	16	18		2	4	6	8	10	12	14	16	18
01	0,48	0,58	0,66	0,72	0,76	0,80	0,82	0,83	0,83	01	0,51	0,61	0,69	0,75	0,79	0,83	0,85	0,86	0,85
02	0,97	1,16	1,31	1,43	1,53	1,60	1,64	1,66	1,65	02	1,02	1,22	1,37	1,50	1,59	1,66	1,70	1,71	1,70
03	1,15	1,37	1,55	1,69	1,80	1,88	1,93	1,94	1,94	03	1,22	1,44	1,62	1,76	1,87	1,95	1,99	2,01	1,99
04	1,85	2,21	2,51	2,75	2,93	3,06	3,14	3,17	3,16	04	1,96	2,33	2,63	2,86	3,04	3,17	3,25	3,28	3,26
05	3,16	3,78	4,28	4,68	4,99	5,21	5,34	5,40	5,38	05	3,35	3,97	4,48	4,88	5,18	5,40	5,53	5,58	5,54
06	4,40	5,24	5,94	6,49	6,92	7,22	7,41	7,48	7,45	06	4,66	5,52	6,22	6,77	7,19	7,49	7,66	7,73	7,68
07	6,91	8,27	9,38	10,27	10,95	11,44	11,74	11,86	11,82	07	7,32	8,70	9,82	10,71	11,37	11,86	12,14	12,25	12,18
08	8,35	9,97	11,29	12,36	13,17	13,75	14,11	14,25	14,20	08	8,84	10,49	11,82	12,88	13,68	14,25	14,59	14,72	14,62
09	9,27	11,05	12,52	13,70	14,59	15,24	15,63	15,78	15,73	09	9,82	11,63	13,11	14,28	15,16	15,79	16,16	16,30	16,19
Evaporating Temperature -10 °C										Evaporating Temperature -20 °C									
Orifice Type	Pressure drop across valve [bar]									Orifice Type	Pressure drop across valve [bar]								
	2	4	6	8	10	12	14	16	18		2	4	6	8	10	12	14	16	18
01	0,54	0,63	0,71	0,77	0,81	0,84	0,86	0,86	0,86	01	0,57	0,64	0,72	0,77	0,81	0,84	0,85	0,85	0,84
02	1,07	1,26	1,41	1,53	1,62	1,68	1,72	1,73	1,71	02	1,13	1,29	1,43	1,54	1,62	1,68	1,70	1,71	1,68
03	1,27	1,49	1,67	1,80	1,90	1,97	2,01	2,03	2,01	03	1,34	1,52	1,69	1,82	1,91	1,97	2,00	2,00	1,97
04	2,05	2,41	2,70	2,93	3,10	3,22	3,29	3,31	3,28	04	2,16	2,47	2,74	2,95	3,11	3,21	3,26	3,27	3,22
05	3,51	4,12	4,61	4,99	5,28	5,48	5,59	5,62	5,57	05	3,70	4,21	4,68	5,03	5,30	5,46	5,55	5,56	5,48
06	4,87	5,72	6,40	6,93	7,32	7,59	7,75	7,80	7,72	06	5,15	5,85	6,49	6,98	7,35	7,58	7,69	7,71	7,60
07	7,66	9,01	10,10	10,96	11,59	12,03	12,29	12,36	12,25	07	8,09	9,22	10,25	11,04	11,63	12,00	12,19	12,22	12,06
08	9,25	10,86	12,17	13,18	13,94	14,46	14,76	14,85	14,71	08	9,77	11,11	12,34	13,29	13,98	14,42	14,65	14,68	14,48
09	10,27	12,05	13,49	14,61	15,45	16,02	16,35	16,45	16,30	09	10,85	12,33	13,69	14,73	15,50	15,98	16,23	16,26	16,04
Evaporating Temperature -30 °C										Evaporating Temperature -40 °C									
Orifice Type	Pressure drop across valve [bar]									Orifice Type	Pressure drop across valve [bar]								
	2	4	6	8	10	12	14	16	18		2	4	6	8	10	12	14	16	18
01	0,57	0,65	0,72	0,77	0,80	0,83	0,83	0,83	0,81	01	0,59	0,66	0,72	0,76	0,79	0,80	0,81	0,79	0,77
02	1,13	1,30	1,44	1,54	1,61	1,65	1,67	1,66	1,63	02	1,17	1,32	1,43	1,52	1,58	1,61	1,61	1,59	1,54
03	1,35	1,54	1,69	1,81	1,89	1,94	1,96	1,95	1,91	03	1,39	1,56	1,69	1,79	1,85	1,89	1,89	1,86	1,81
04	2,17	2,49	2,75	2,94	3,08	3,16	3,20	3,18	3,12	04	2,24	2,52	2,75	2,91	3,02	3,08	3,08	3,04	2,95
05	3,72	4,26	4,69	5,01	5,25	5,39	5,44	5,41	5,31	05	3,84	4,31	4,69	4,96	5,14	5,24	5,25	5,17	5,02
06	5,16	5,91	6,51	6,96	7,28	7,47	7,54	7,50	7,36	06	5,33	5,98	6,50	6,88	7,13	7,26	7,28	7,17	6,96
07	8,11	9,32	10,28	11,00	11,52	11,83	11,95	11,90	11,67	07	8,38	9,43	10,27	10,88	11,29	11,50	11,53	11,37	11,05
08	9,80	11,24	12,38	13,23	13,85	14,22	14,36	14,29	14,01	08	10,12	11,37	12,36	13,09	13,57	13,82	13,86	13,65	13,26
09	10,88	12,47	13,72	14,67	15,35	15,75	15,91	15,83	15,52	09	11,24	12,62	13,71	14,51	15,04	15,31	15,35	15,12	14,69

**TABLE 18B - Correction factors for subcooling  $\Delta t_{sub} \neq 4^\circ K$**

$\Delta t_{sub} [^\circ K]$	4	10	15	20	25	30	35	40	45
Fsub	1,00	1,09	1,17	1,26	1,34	1,42	1,50	1,56	1,63

When subcooling ahead of the expansion valve is other than 4 °K , adjust the evaporator capacity by dividing by the appropriate correction factor found in Table 18B

**TABLE 19A: Refrigerant R407C - Capacities in kW**

Evaporating Temperature 10 °C										Evaporating Temperature 0 °C									
Orifice Type	Pressure drop across valve [bar]									Orifice Type	Pressure drop across valve [bar]								
	2	4	6	8	10	12	14	16	18		2	4	6	8	10	12	14	16	18
01	0,76	0,93	1,09	1,23	1,36	1,48	1,58	1,66	1,74	01	0,78	0,96	1,12	1,26	1,39	1,50	1,60	1,69	1,76
02	1,52	1,87	2,18	2,47	2,72	2,95	3,15	3,33	3,48	02	1,57	1,92	2,24	2,52	2,77	3,00	3,20	3,37	3,52
03	1,80	2,21	2,57	2,91	3,20	3,47	3,70	3,91	4,08	03	1,86	2,27	2,64	2,97	3,26	3,52	3,76	3,96	4,13
04	2,90	3,57	4,18	4,72	5,21	5,65	6,04	6,37	6,66	04	3,00	3,68	4,28	4,82	5,31	5,74	6,13	6,46	6,75
05	4,96	6,10	7,13	8,05	8,87	9,62	10,27	10,84	11,33	05	5,14	6,28	7,30	8,22	9,05	9,77	10,42	10,99	11,47
06	6,89	8,47	9,89	11,17	12,31	13,33	14,24	15,03	15,71	06	7,14	8,72	10,13	11,41	12,54	13,55	14,45	15,23	15,90
07	10,83	13,35	15,62	17,66	19,48	21,12	22,57	23,83	24,91	07	11,22	13,74	16,00	18,04	19,86	21,47	22,91	24,15	25,23
08	13,09	16,09	18,81	21,25	23,42	25,38	27,11	28,62	29,92	08	13,55	16,57	19,27	21,70	23,88	25,80	27,52	29,01	30,29
09	14,53	17,85	20,85	23,55	25,96	28,13	30,04	31,71	33,14	09	15,04	18,38	21,37	24,06	26,46	28,59	30,49	32,14	33,55
Evaporating Temperature -10 °C										Evaporating Temperature -20 °C									
Orifice Type	Pressure drop across valve [bar]									Orifice Type	Pressure drop across valve [bar]								
	2	4	6	8	10	12	14	16	18		2	4	6	8	10	12	14	16	18
01	0,81	0,98	1,14	1,28	1,40	1,51	1,61	1,70	1,77	01	0,83	1,00	1,15	1,28	1,40	1,51	1,60	1,68	1,75
02	1,62	1,97	2,28	2,56	2,81	3,03	3,22	3,39	3,54	02	1,65	1,99	2,30	2,57	2,81	3,02	3,20	3,36	3,50
03	1,92	2,33	2,69	3,01	3,30	3,56	3,78	3,98	4,15	03	1,96	2,36	2,71	3,02	3,30	3,55	3,76	3,95	4,11
04	3,10	3,77	4,36	4,90	5,38	5,80	6,17	6,49	6,77	04	3,16	3,81	4,39	4,91	5,37	5,78	6,13	6,44	6,71
05	5,31	6,44	7,44	8,35	9,16	9,87	10,50	11,05	11,52	05	5,42	6,51	7,49	8,37	9,15	9,84	10,43	10,96	11,40
06	7,37	8,93	10,33	11,59	12,70	13,69	14,55	15,31	15,96	06	7,52	9,04	10,40	11,61	12,69	13,64	14,46	15,19	15,80
07	11,58	14,08	16,31	18,32	20,10	21,68	23,07	24,28	25,32	07	11,82	14,26	16,42	18,37	20,08	21,61	22,92	24,08	25,07
08	13,99	16,98	19,64	22,04	24,16	26,06	27,71	29,16	30,41	08	14,28	17,19	19,78	22,10	24,15	25,97	27,54	28,92	30,10
09	15,53	18,84	21,78	24,43	26,78	28,87	30,70	32,30	33,68	09	15,85	19,06	21,93	24,49	26,76	28,78	30,51	32,04	33,35
Evaporating Temperature -30 °C										Evaporating Temperature -40 °C									
Orifice Type	Pressure drop across valve [bar]									Orifice Type	Pressure drop across valve [bar]								
	2	4	6	8	10	12	14	16	18		2	4	6	8	10	12	14	16	18
01	0,84	1,00	1,15	1,27	1,39	1,49	1,58	1,65	1,72	01	0,85	1,01	1,15	1,27	1,38	1,48	1,56	1,63	1,69
02	1,67	2,00	2,29	2,55	2,78	2,98	3,16	3,31	3,43	02	1,71	2,02	2,30	2,54	2,76	2,96	3,12	3,26	3,38
03	1,99	2,37	2,70	3,00	3,27	3,50	3,71	3,88	4,03	03	2,03	2,38	2,71	3,00	3,25	3,47	3,66	3,83	3,97
04	3,20	3,83	4,39	4,88	5,32	5,71	6,04	6,33	6,58	04	3,26	3,86	4,39	4,87	5,29	5,66	5,98	6,25	6,48
05	5,48	6,54	7,48	8,32	9,06	9,71	10,29	10,77	11,18	05	5,59	6,59	7,49	8,30	9,01	9,64	10,17	10,63	11,01
06	7,62	9,08	10,38	11,54	12,57	13,47	14,26	14,93	15,50	06	7,76	9,15	10,40	11,52	12,50	13,36	14,10	14,74	15,26
07	11,97	14,31	16,40	18,25	19,90	21,34	22,60	23,67	24,58	07	12,20	14,43	16,42	18,21	19,78	21,16	22,34	23,37	24,21
08	14,46	17,25	19,74	21,95	23,92	25,64	27,15	28,43	29,52	08	14,73	17,39	19,78	21,91	23,79	25,44	26,84	28,07	29,07
09	16,05	19,13	21,89	24,33	26,51	28,41	30,08	31,50	32,70	09	16,35	19,29	21,93	24,29	26,36	28,19	29,74	31,10	32,21

**TABLE: 19B - Correction factor for subcooling  $\Delta t_{sub} \neq 4^\circ K$**

$\Delta t_{sub} [^\circ K]$	4	10	15	20	25	30	35	40	45
Fsub	1,00	1,06	1,12	1,19	1,25	1,31	1,37	1,44	1,49

When subcooling ahead of the expansion valve is other than 4 °K , adjust the evaporator capacity by dividing by the appropriate correction factor found in Table 19B

**TABLE 20A: Refrigerant R410A - Capacities in kW**

Evaporating Temperature 10 °C										Evaporating Temperature 0 °C									
Orifice Type	Pressure drop across valve [bar]									Orifice Type	Pressure drop across valve [bar]								
	2	4	6	8	10	12	14	16	18		2	4	6	8	10	12	14	16	18
01	0,63	0,78	0,91	1,02	1,12	1,21	1,28	1,35	1,40	01	0,68	0,83	0,96	1,08	1,19	1,28	1,36	1,42	1,48
02	1,27	1,56	1,82	2,05	2,25	2,42	2,57	2,69	2,79	02	1,35	1,66	1,93	2,17	2,37	2,56	2,71	2,84	2,95
03	1,50	1,84	2,14	2,41	2,64	2,85	3,02	3,16	3,27	03	1,61	1,96	2,27	2,55	2,79	3,00	3,18	3,34	3,46
04	2,42	2,98	3,48	3,92	4,30	4,64	4,92	5,16	5,35	04	2,59	3,17	3,69	4,15	4,55	4,89	5,20	5,45	5,65
05	4,14	5,09	5,93	6,68	7,33	7,90	8,37	8,77	9,09	05	4,43	5,42	6,30	7,07	7,74	8,33	8,84	9,27	9,61
06	5,76	7,07	8,23	9,26	10,16	10,95	11,61	12,16	12,60	06	6,16	7,53	8,73	9,80	10,74	11,55	12,26	12,85	13,32
07	9,05	11,14	13,00	14,64	16,09	17,34	18,40	19,29	19,99	07	9,68	11,87	13,79	15,50	17,00	18,30	19,42	20,37	21,14
08	10,93	13,43	15,65	17,62	19,35	20,84	22,10	23,16	24,00	08	11,69	14,31	16,61	18,65	20,44	21,99	23,34	24,47	25,38
09	12,13	14,90	17,35	19,53	21,44	23,09	24,49	25,66	26,58	09	12,98	15,87	18,42	20,68	22,65	24,37	25,85	27,10	28,11
Evaporating Temperature -10 °C										Evaporating Temperature -20 °C									
Orifice Type	Pressure drop across valve [bar]									Orifice Type	Pressure drop across valve [bar]								
	2	4	6	8	10	12	14	16	18		2	4	6	8	10	12	14	16	18
01	0,77	0,93	1,07	1,20	1,31	1,40	1,49	1,56	1,62	01	0,75	0,90	1,04	1,16	1,26	1,36	1,43	1,50	1,55
02	1,54	1,86	2,14	2,39	2,62	2,81	2,97	3,11	3,23	02	1,49	1,80	2,08	2,32	2,53	2,71	2,86	3,00	3,10
03	1,83	2,20	2,53	2,82	3,08	3,30	3,49	3,65	3,79	03	1,77	2,13	2,45	2,73	2,97	3,18	3,36	3,52	3,64
04	2,95	3,56	4,10	4,58	5,01	5,37	5,69	5,97	6,19	04	2,85	3,45	3,97	4,44	4,84	5,19	5,49	5,74	5,94
05	5,04	6,08	7,00	7,81	8,53	9,15	9,69	10,15	10,53	05	4,89	5,90	6,78	7,56	8,24	8,83	9,34	9,76	10,11
06	7,01	8,44	9,72	10,84	11,83	12,68	13,43	14,07	14,59	06	6,79	8,18	9,41	10,49	11,43	12,25	12,94	13,53	14,01
07	11,01	13,31	15,34	17,14	18,72	20,09	21,29	22,31	23,14	07	10,67	12,90	14,86	16,59	18,09	19,40	20,52	21,45	22,23
08	13,30	16,05	18,48	20,62	22,51	24,15	25,57	26,79	27,79	08	12,89	15,55	17,89	19,96	21,76	23,32	24,65	25,77	26,69
09	14,76	17,80	20,49	22,85	24,95	26,76	28,33	29,68	30,78	09	14,31	17,25	19,84	22,13	24,11	25,84	27,31	28,55	29,56
Evaporating Temperature -30 °C										Evaporating Temperature -40 °C									
Orifice Type	Pressure drop across valve [bar]									Orifice Type	Pressure drop across valve [bar]								
	2	4	6	8	10	12	14	16	18		2	4	6	8	10	12	14	16	18
01	0,77	0,92	1,06	1,18	1,28	1,37	1,44	1,50	1,56	01	0,79	0,94	1,07	1,18	1,28	1,37	1,44	1,50	1,55
02	1,54	1,85	2,12	2,35	2,56	2,73	2,89	3,01	3,11	02	1,58	1,88	2,14	2,36	2,56	2,73	2,88	3,00	3,09
03	1,83	2,19	2,50	2,77	3,01	3,21	3,39	3,53	3,65	03	1,88	2,22	2,52	2,78	3,01	3,21	3,38	3,52	3,63
04	2,95	3,54	4,05	4,50	4,89	5,24	5,53	5,76	5,97	04	3,02	3,59	4,09	4,53	4,90	5,24	5,51	5,74	5,92
05	5,06	6,04	6,91	7,67	8,33	8,91	9,40	9,80	10,14	05	5,17	6,13	6,97	7,71	8,35	8,91	9,37	9,77	10,07
06	7,03	8,39	9,59	10,64	11,56	12,36	13,03	13,59	14,06	06	7,19	8,51	9,67	10,70	11,58	12,36	12,99	13,54	13,96
07	11,04	13,22	15,14	16,83	18,30	19,58	20,66	21,54	22,30	07	11,30	13,41	15,28	16,92	18,33	19,58	20,60	21,47	22,15
08	13,34	15,94	18,23	20,25	22,00	23,53	24,82	25,87	26,78	08	13,65	16,17	18,40	20,35	22,04	23,53	24,74	25,79	26,59
09	14,80	17,68	20,22	22,45	24,38	26,07	27,50	28,66	29,67	09	15,15	17,94	20,40	22,56	24,43	26,07	27,41	28,57	29,46

**TABLE 20B - Correction factors for subcooling  $\Delta t_{sub} \neq 4^\circ K$**

$\Delta t_{sub} [^\circ K]$	4	10	15	20	25	30	35	40	45
Fsub	1,00	1,07	1,14	1,21	1,28	1,34	1,41	1,48	1,54

When subcooling ahead of the expansion valve is other than 4 °K , adjust the evaporator capacity by dividing by the appropriate correction factor found in Table 20B

**TABLE 21A: Refrigerant R507A - Capacities in kW**

Evaporating Temperature 10 °C										Evaporating Temperature 0 °C									
Orifice Type	Pressure drop across valve [bar]									Orifice Type	Pressure drop across valve [bar]								
	2	4	6	8	10	12	14	16	18		2	4	6	8	10	12	14	16	18
01	0,50	0,60	0,68	0,74	0,80	0,84	0,86	0,87	0,87	01	0,52	0,63	0,71	0,78	0,83	0,87	0,89	0,90	0,90
02	0,99	1,19	1,36	1,49	1,59	1,67	1,72	1,74	1,74	02	1,05	1,25	1,42	1,55	1,65	1,73	1,78	1,80	1,80
03	1,18	1,41	1,60	1,75	1,88	1,96	2,02	2,04	2,04	03	1,24	1,48	1,67	1,83	1,95	2,03	2,09	2,11	2,11
04	1,90	2,28	2,60	2,85	3,05	3,20	3,29	3,33	3,32	04	2,00	2,39	2,71	2,97	3,17	3,31	3,41	3,45	3,44
05	3,25	3,89	4,43	4,86	5,20	5,44	5,60	5,67	5,65	05	3,43	4,09	4,62	5,06	5,40	5,64	5,80	5,87	5,85
06	4,51	5,40	6,15	6,74	7,21	7,55	7,76	7,86	7,83	06	4,76	5,67	6,41	7,02	7,48	7,82	8,04	8,13	8,10
07	7,09	8,52	9,71	10,66	11,42	11,96	12,30	12,47	12,43	07	7,49	8,94	10,13	11,10	11,84	12,39	12,74	12,89	12,86
08	8,57	10,27	11,69	12,83	13,73	14,37	14,78	14,97	14,92	08	9,05	10,78	12,20	13,35	14,24	14,89	15,30	15,49	15,44
09	9,51	11,39	12,96	14,22	15,21	15,92	16,38	16,59	16,53	09	10,04	11,96	13,53	14,80	15,78	16,50	16,95	17,16	17,10
Evaporating Temperature -10 °C										Evaporating Temperature -20 °C									
Orifice Type	Pressure drop across valve [bar]									Orifice Type	Pressure drop across valve [bar]								
	2	4	6	8	10	12	14	16	18		2	4	6	8	10	12	14	16	18
01	0,55	0,65	0,73	0,79	0,84	0,88	0,90	0,91	0,91	01	0,57	0,66	0,74	0,80	0,85	0,88	0,90	0,90	0,90
02	1,09	1,29	1,45	1,59	1,68	1,76	1,80	1,82	1,81	02	1,13	1,32	1,48	1,60	1,69	1,76	1,80	1,81	1,80
03	1,30	1,53	1,72	1,87	1,98	2,06	2,11	2,14	2,12	03	1,34	1,57	1,75	1,89	1,99	2,07	2,11	2,12	2,11
04	2,09	2,47	2,78	3,04	3,23	3,36	3,45	3,49	3,47	04	2,16	2,53	2,83	3,07	3,25	3,37	3,44	3,46	3,44
05	3,58	4,22	4,75	5,17	5,49	5,72	5,87	5,93	5,90	05	3,70	4,33	4,83	5,23	5,53	5,74	5,85	5,89	5,85
06	4,97	5,86	6,59	7,18	7,62	7,94	8,14	8,22	8,18	06	5,15	6,01	6,70	7,25	7,67	7,96	8,12	8,16	8,10
07	7,81	9,24	10,41	11,35	12,06	12,57	12,90	13,04	12,97	07	8,09	9,47	10,59	11,47	12,13	12,60	12,86	12,95	12,86
08	9,43	11,14	12,53	13,65	14,50	15,11	15,49	15,66	15,58	08	9,77	11,42	12,75	13,80	14,59	15,14	15,45	15,55	15,44
09	10,47	12,36	13,89	15,13	16,07	16,74	17,17	17,34	17,26	09	10,85	12,67	14,14	15,29	16,17	16,78	17,12	17,23	17,10
Evaporating Temperature -30 °C										Evaporating Temperature -40 °C									
Orifice Type	Pressure drop across valve [bar]									Orifice Type	Pressure drop across valve [bar]								
	2	4	6	8	10	12	14	16	18		2	4	6	8	10	12	14	16	18
01	0,58	0,67	0,74	0,80	0,84	0,87	0,88	0,88	0,87	01	0,59	0,67	0,74	0,79	0,83	0,85	0,86	0,85	0,86
02	1,16	1,34	1,48	1,60	1,68	1,73	1,76	1,77	1,74	02	1,18	1,34	1,48	1,58	1,65	1,70	1,71	1,71	1,73
03	1,37	1,58	1,75	1,88	1,97	2,04	2,07	2,07	2,04	03	1,40	1,59	1,74	1,86	1,94	1,99	2,01	2,00	2,03
04	2,21	2,56	2,84	3,06	3,21	3,32	3,38	3,38	3,34	04	2,25	2,57	2,83	3,02	3,16	3,25	3,28	3,27	3,31
05	3,79	4,37	4,84	5,21	5,47	5,65	5,75	5,75	5,68	05	3,86	4,39	4,82	5,15	5,38	5,53	5,58	5,56	5,63
06	5,26	6,07	6,72	7,22	7,59	7,84	7,96	7,97	7,87	06	5,36	6,10	6,69	7,14	7,47	7,67	7,74	7,71	7,80
07	8,27	9,57	10,61	11,42	12,01	12,42	12,62	12,65	12,49	07	8,42	9,61	10,57	11,29	11,82	12,14	12,27	12,22	12,37
08	9,99	11,54	12,77	13,74	14,44	14,92	15,17	15,19	14,99	08	10,17	11,59	12,73	13,59	14,21	14,59	14,74	14,68	14,85
09	11,09	12,80	14,16	15,24	16,00	16,53	16,80	16,82	16,61	09	11,29	12,86	14,11	15,06	15,75	16,17	16,33	16,26	16,45

**TABLE: 21B - Correction factor for subcooling  $\Delta t_{sub} \neq 4^\circ K$**

$\Delta t_{sub} [^\circ K]$	4	10	15	20	25	30	35	40	45
$F_{sub}$	1,00	1,09	1,18	1,26	1,35	1,44	1,52	1,60	1,67

When subcooling ahead of the expansion valve is other than 4 °K , adjust the evaporator capacity by dividing by the appropriate correction factor found in Table 21B

**TABLE 22A: Refrigerant R1234yf - Capacities in kW**

Evaporating Temperature 20 °C										Evaporating Temperature 10 °C									
Orifice Type	Pressure drop across valve [bar]									Orifice Type	Pressure drop across valve [bar]								
	2	4	6	8	10	12	14	16	18		2	4	6	8	10	12	14	16	18
01	0,47	0,55	0,61	0,65	0,67	0,68	0,67	0,65	0,61	01	0,49	0,57	0,62	0,66	0,68	0,68	0,67	0,65	0,61
02	0,94	1,10	1,21	1,29	1,34	1,36	1,34	1,30	1,23	02	0,98	1,13	1,24	1,32	1,36	1,37	1,35	1,30	1,22
03	1,12	1,30	1,43	1,52	1,58	1,60	1,58	1,52	1,44	03	1,17	1,34	1,47	1,55	1,60	1,61	1,58	1,52	1,43
04	1,80	2,10	2,32	2,48	2,57	2,60	2,57	2,49	2,35	04	1,88	2,17	2,38	2,52	2,60	2,62	2,58	2,49	2,33
05	3,08	3,59	3,96	4,22	4,37	4,43	4,38	4,23	4,00	05	3,21	3,71	4,06	4,30	4,43	4,46	4,39	4,23	3,97
06	4,28	4,98	5,50	5,85	6,07	6,14	6,07	5,87	5,54	06	4,47	5,14	5,63	5,96	6,15	6,18	6,09	5,87	5,50
07	6,73	7,85	8,68	9,26	9,60	9,72	9,62	9,31	8,79	07	7,02	8,11	8,89	9,43	9,73	9,79	9,66	9,31	8,73
08	8,13	9,46	10,46	11,14	11,54	11,69	11,56	11,18	10,55	08	8,48	9,78	10,71	11,35	11,70	11,77	11,60	11,18	10,48
09	9,02	10,50	11,59	12,35	12,79	12,95	12,81	12,38	11,69	09	9,41	10,85	11,88	12,58	12,96	13,04	12,85	12,38	11,61
Evaporating Temperature 0 °C										Evaporating Temperature -10 °C									
Orifice Type	Pressure drop across valve [bar]									Orifice Type	Pressure drop across valve [bar]								
	2	4	6	8	10	12	14	16	18		2	4	6	8	10	12	14	16	18
01	0,50	0,58	0,63	0,66	0,67	0,67	0,66	0,63	0,58	01	0,51	0,58	0,62	0,65	0,66	0,65	0,63	0,60	0,55
02	1,01	1,15	1,25	1,31	1,35	1,35	1,32	1,26	1,17	02	1,02	1,15	1,24	1,29	1,31	1,30	1,26	1,19	1,09
03	1,20	1,36	1,48	1,55	1,58	1,58	1,55	1,48	1,37	03	1,22	1,36	1,46	1,52	1,54	1,53	1,48	1,40	1,28
04	1,93	2,20	2,39	2,52	2,58	2,58	2,52	2,41	2,24	04	1,96	2,21	2,38	2,48	2,51	2,49	2,42	2,28	2,09
05	3,30	3,76	4,08	4,29	4,39	4,39	4,29	4,10	3,81	05	3,36	3,77	4,05	4,22	4,28	4,24	4,11	3,88	3,55
06	4,59	5,22	5,67	5,95	6,09	6,08	5,95	5,68	5,28	06	4,66	5,23	5,63	5,85	5,94	5,89	5,70	5,38	4,92
07	7,21	8,23	8,95	9,41	9,64	9,64	9,43	9,00	8,38	07	7,33	8,25	8,89	9,26	9,40	9,32	9,03	8,52	7,81
08	8,71	9,92	10,78	11,32	11,59	11,58	11,33	10,81	10,06	08	8,85	9,95	10,70	11,14	11,30	11,20	10,85	10,24	9,38
09	9,67	11,00	11,95	12,55	12,84	12,83	12,55	11,98	11,14	09	9,83	11,03	11,86	12,35	12,53	12,41	12,02	11,34	10,39
Evaporating Temperature -20 °C										Evaporating Temperature -30 °C									
Orifice Type	Pressure drop across valve [bar]									Orifice Type	Pressure drop across valve [bar]								
	2	4	6	8	10	12	14	16	18		2	4	6	8	10	12	14	16	18
01	0,52	0,57	0,61	0,63	0,63	0,62	0,59	0,55	0,50	01	0,51	0,56	0,59	0,60	0,60	0,58	0,55	0,50	0,44
02	1,03	1,14	1,22	1,26	1,26	1,23	1,18	1,10	0,99	02	1,03	1,12	1,18	1,21	1,20	1,16	1,09	1,00	0,87
03	1,23	1,35	1,44	1,48	1,48	1,45	1,39	1,29	1,16	03	1,22	1,33	1,39	1,42	1,41	1,36	1,28	1,17	1,02
04	1,97	2,19	2,33	2,41	2,42	2,36	2,27	2,11	1,90	04	1,97	2,15	2,26	2,31	2,29	2,22	2,09	1,91	1,67
05	3,38	3,74	3,98	4,10	4,12	4,02	3,85	3,59	3,23	05	3,37	3,67	3,86	3,93	3,91	3,78	3,56	3,25	2,84
06	4,70	5,19	5,52	5,69	5,71	5,58	5,34	4,97	4,47	06	4,68	5,10	5,35	5,46	5,42	5,24	4,94	4,50	3,94
07	7,38	8,18	8,71	9,00	9,03	8,84	8,47	7,89	7,09	07	7,36	8,04	8,45	8,63	8,58	8,31	7,83	7,14	6,25
08	8,91	9,87	10,49	10,83	10,86	10,62	10,17	9,47	8,51	08	8,89	9,69	10,18	10,38	10,32	9,98	9,40	8,57	7,51
09	9,89	10,95	11,63	12,00	12,04	11,77	11,27	10,49	9,43	09	9,86	10,75	11,29	11,51	11,43	11,06	10,42	9,50	8,32

**TABLE 22B - Correction factors for subcooling  $\Delta t_{sub} \neq 4^\circ K$**

$\Delta t_{sub} [^\circ K]$	4	10	15	20	25	30	35	40	45
Fsub	1,00	1,07	1,15	1,22	1,29	1,36	1,43	1,49	1,55

When subcooling ahead of the expansion valve is other than 4 °K , adjust the evaporator capacity by dividing by the appropriate correction factor found in Table 22B

**TABLE 23A: Refrigerant R1234ze - Capacities in kW**

Evaporating Temperature 20 °C										Evaporating Temperature 10 °C									
Orifice Type	Pressure drop across valve [bar]									Orifice Type	Pressure drop across valve [bar]								
	2	4	6	8	10	12	14	16	18		2	4	6	8	10	12	14	16	18
01	0,54	0,62	0,69	0,74	0,77	0,79	0,79	0,78	0,75	01	0,55	0,63	0,70	0,74	0,77	0,78	0,77	0,76	0,72
02	1,07	1,25	1,38	1,48	1,54	1,58	1,58	1,55	1,50	02	1,10	1,27	1,39	1,48	1,53	1,55	1,55	1,51	1,45
03	1,27	1,48	1,63	1,74	1,82	1,85	1,86	1,82	1,76	03	1,31	1,50	1,64	1,74	1,80	1,83	1,82	1,78	1,70
04	2,05	2,39	2,65	2,83	2,96	3,02	3,03	2,98	2,88	04	2,11	2,42	2,66	2,83	2,93	2,98	2,96	2,90	2,78
05	3,52	4,08	4,51	4,83	5,03	5,14	5,15	5,07	4,89	05	3,61	4,14	4,54	4,82	4,99	5,07	5,04	4,93	4,72
06	4,88	5,67	6,26	6,70	6,98	7,13	7,14	7,02	6,78	06	5,02	5,75	6,30	6,69	6,93	7,02	6,99	6,83	6,55
07	7,68	8,94	9,89	10,60	11,05	11,30	11,32	11,14	10,75	07	7,88	9,06	9,96	10,58	10,96	11,13	11,08	10,83	10,38
08	9,27	10,77	11,91	12,75	13,29	13,58	13,60	13,37	12,91	08	9,52	10,93	11,99	12,72	13,18	13,37	13,32	13,01	12,47
09	10,29	11,95	13,21	14,13	14,72	15,05	15,07	14,82	14,30	09	10,57	12,12	13,29	14,10	14,61	14,82	14,75	14,41	13,81
Evaporating Temperature 0 °C										Evaporating Temperature -10 °C									
Orifice Type	Pressure drop across valve [bar]									Orifice Type	Pressure drop across valve [bar]								
	2	4	6	8	10	12	14	16	18		2	4	6	8	10	12	14	16	18
01	0,56	0,64	0,69	0,73	0,75	0,76	0,66	0,63	0,58	01	0,56	0,63	0,68	0,71	0,72	0,72	0,70	0,67	0,63
02	1,13	1,28	1,39	1,46	1,50	1,52	1,31	1,25	1,17	02	1,13	1,26	1,36	1,42	1,44	1,44	1,41	1,35	1,26
03	1,34	1,51	1,64	1,72	1,77	1,78	1,54	1,47	1,37	03	1,34	1,49	1,60	1,67	1,70	1,69	1,65	1,58	1,48
04	2,16	2,45	2,66	2,80	2,88	2,90	2,51	2,40	2,24	04	2,16	2,41	2,59	2,71	2,76	2,76	2,69	2,58	2,41
05	3,69	4,18	4,54	4,77	4,91	4,94	4,27	4,09	3,81	05	3,69	4,12	4,43	4,62	4,71	4,69	4,58	4,39	4,10
06	5,13	5,80	6,29	6,62	6,81	6,85	5,92	5,67	5,28	06	5,13	5,73	6,14	6,41	6,53	6,51	6,36	6,08	5,69
07	8,07	9,14	9,94	10,47	10,77	10,85	9,38	8,99	8,38	07	8,07	9,02	9,70	10,14	10,33	10,31	10,07	9,64	9,02
08	9,74	11,02	11,97	12,59	12,95	13,05	11,27	10,79	10,06	08	9,74	10,88	11,68	12,20	12,42	12,39	12,10	11,58	10,83
09	10,81	12,23	13,27	13,96	14,36	14,46	12,49	11,96	11,14	09	10,81	12,07	12,95	13,52	13,77	13,73	13,41	12,83	12,00
Evaporating Temperature -20 °C										Evaporating Temperature -30 °C									
Orifice Type	Pressure drop across valve [bar]									Orifice Type	Pressure drop across valve [bar]								
	2	4	6	8	10	12	14	16	18		2	4	6	8	10	12	14	16	18
01	0,57	0,62	0,66	0,69	0,69	0,68	0,66	0,62	0,57	01	0,56	0,60	0,63	0,65	0,65	0,63	0,60	0,56	0,50
02	1,13	1,25	1,33	1,37	1,38	1,37	1,32	1,24	1,15	02	1,12	1,21	1,27	1,30	1,30	1,26	1,20	1,11	1,00
03	1,35	1,47	1,56	1,61	1,63	1,61	1,55	1,46	1,34	03	1,32	1,43	1,50	1,53	1,53	1,49	1,41	1,31	1,17
04	2,17	2,39	2,54	2,62	2,65	2,62	2,53	2,38	2,19	04	2,13	2,31	2,43	2,49	2,48	2,42	2,30	2,13	1,91
05	3,72	4,08	4,33	4,47	4,51	4,45	4,30	4,06	3,73	05	3,65	3,95	4,15	4,24	4,23	4,12	3,92	3,63	3,25
06	5,16	5,66	6,01	6,21	6,26	6,17	5,96	5,62	5,17	06	5,07	5,48	5,75	5,88	5,87	5,71	5,43	5,03	4,51
07	8,11	8,92	9,49	9,81	9,90	9,78	9,45	8,92	8,20	07	7,97	8,64	9,09	9,30	9,29	9,05	8,61	7,97	7,15
08	9,80	10,76	11,43	11,81	11,91	11,75	11,35	10,71	9,85	08	9,63	10,41	10,94	11,19	11,17	10,88	10,35	9,58	8,58
09	10,88	11,93	12,67	13,09	13,20	13,02	12,58	11,86	10,91	09	10,69	11,55	12,13	12,41	12,37	12,05	11,46	10,61	9,51

**TABLE: 23B - Correction factor for subcooling  $\Delta t_{sub} \neq 4^\circ K$**

$\Delta t_{sub} [^\circ K]$	4	10	15	20	25	30	35	40	45
Fsub	1,00	1,06	1,12	1,18	1,24	1,30	1,36	1,44	1,49

When subcooling ahead of the expansion valve is other than 4 °K , adjust the evaporator capacity by dividing by the appropriate correction factor found in Table 23B

**TABLE 24A: Refrigerant R448A - Capacities in kW**

Evaporating Temperature 10 °C										Evaporating Temperature 0 °C									
Orifice Type	Pressure drop across valve [bar]									Orifice Type	Pressure drop across valve [bar]								
	2	4	6	8	10	12	14	16	18		2	4	6	8	10	12	14	16	18
01	0,63	0,77	0,89	1,00	1,09	1,17	1,24	1,29	1,33	01	0,66	0,80	0,93	1,03	1,13	1,20	1,27	1,32	1,36
02	1,26	1,54	1,79	2,00	2,19	2,35	2,48	2,58	2,66	02	1,32	1,61	1,85	2,07	2,25	2,41	2,54	2,64	2,73
03	1,50	1,83	2,11	2,36	2,58	2,76	2,91	3,03	3,12	03	1,57	1,90	2,19	2,43	2,65	2,83	2,98	3,10	3,20
04	2,42	2,96	3,43	3,84	4,19	4,49	4,74	4,94	5,10	04	2,53	3,07	3,55	3,96	4,31	4,61	4,86	5,06	5,22
05	4,14	5,05	5,84	6,54	7,14	7,65	8,07	8,41	8,67	05	4,34	5,25	6,05	6,75	7,35	7,85	8,27	8,61	8,88
06	5,75	7,01	8,11	9,07	9,90	10,60	11,19	11,66	12,02	06	6,02	7,29	8,40	9,36	10,19	10,88	11,47	11,94	12,30
07	9,04	11,05	12,81	14,34	15,67	16,80	17,74	18,49	19,07	07	9,47	11,49	13,26	14,80	16,13	17,24	18,17	18,93	19,52
08	10,92	13,32	15,42	17,25	18,85	20,19	21,31	22,20	22,90	08	11,44	13,86	15,97	17,80	19,39	20,72	21,83	22,74	23,44
09	12,13	14,78	17,10	19,12	20,89	22,37	23,61	24,60	25,37	09	12,69	15,37	17,71	19,73	21,49	22,96	24,19	25,19	25,96
Evaporating Temperature -10 °C										Evaporating Temperature -20 °C									
Orifice Type	Pressure drop across valve [bar]									Orifice Type	Pressure drop across valve [bar]								
	2	4	6	8	10	12	14	16	18		2	4	6	8	10	12	14	16	18
01	0,69	0,83	0,95	1,05	1,14	1,22	1,20	1,25	1,28	01	0,71	0,84	0,96	1,06	1,15	1,22	1,28	1,33	1,36
02	1,37	1,65	1,90	2,11	2,29	2,44	2,41	2,50	2,57	02	1,41	1,68	1,92	2,12	2,30	2,44	2,56	2,66	2,73
03	1,63	1,96	2,24	2,48	2,69	2,87	2,83	2,94	3,01	03	1,68	1,99	2,27	2,50	2,70	2,87	3,01	3,12	3,20
04	2,63	3,16	3,63	4,03	4,38	4,67	4,61	4,79	4,92	04	2,70	3,22	3,68	4,07	4,40	4,68	4,91	5,09	5,22
05	4,50	5,41	6,19	6,87	7,46	7,95	7,85	8,15	8,36	05	4,62	5,50	6,27	6,93	7,49	7,96	8,35	8,65	8,88
06	6,25	7,50	8,60	9,54	10,35	11,03	10,88	11,30	11,59	06	6,42	7,64	8,70	9,61	10,39	11,04	11,58	12,00	12,30
07	9,82	11,83	13,58	15,08	16,38	17,47	17,24	17,92	18,39	07	10,09	12,05	13,74	15,20	16,44	17,48	18,35	19,02	19,52
08	11,86	14,26	16,35	18,14	19,70	21,00	20,72	21,52	22,08	08	12,19	14,52	16,55	18,29	19,77	21,01	22,04	22,84	23,44
09	13,16	15,82	18,12	20,11	21,83	23,27	22,95	23,84	24,46	09	13,53	16,11	18,35	20,27	21,91	23,28	24,42	25,31	25,96
Evaporating Temperature -30 °C										Evaporating Temperature -40 °C									
Orifice Type	Pressure drop across valve [bar]									Orifice Type	Pressure drop across valve [bar]								
	2	4	6	8	10	12	14	16	18		2	4	6	8	10	12	14	16	18
01	0,72	0,85	0,96	1,06	1,14	1,21	1,27	1,31	1,34	01	0,73	0,86	0,96	1,05	1,13	1,19	1,24	1,28	1,31
02	1,44	1,70	1,93	2,12	2,29	2,42	2,53	2,62	2,68	02	1,47	1,71	1,93	2,11	2,26	2,39	2,49	2,56	2,61
03	1,71	2,01	2,27	2,50	2,69	2,85	2,97	3,07	3,14	03	1,74	2,03	2,27	2,48	2,66	2,81	2,92	3,01	3,06
04	2,75	3,26	3,69	4,06	4,38	4,64	4,85	5,01	5,13	04	2,81	3,28	3,69	4,04	4,33	4,57	4,76	4,91	5,00
05	4,72	5,56	6,30	6,92	7,46	7,90	8,26	8,52	8,73	05	4,81	5,60	6,30	6,88	7,38	7,78	8,10	8,35	8,51
06	6,55	7,72	8,73	9,60	10,34	10,95	11,45	11,82	12,10	06	6,68	7,78	8,73	9,55	10,23	10,79	11,23	11,57	11,79
07	10,30	12,17	13,79	15,19	16,37	17,34	18,14	18,74	19,19	07	10,50	12,26	13,79	15,10	16,19	17,10	17,80	18,35	18,70
08	12,44	14,67	16,61	18,27	19,68	20,84	21,79	22,50	23,04	08	12,69	14,78	16,61	18,17	19,47	20,55	21,39	22,03	22,45
09	13,81	16,28	18,42	20,26	21,81	23,09	24,15	24,93	25,52	09	14,08	16,40	18,42	20,14	21,58	22,77	23,70	24,41	24,87

**TABLE 24B - Correction factors for subcooling  $\Delta t_{sub} \neq 4^\circ K$**

$\Delta t_{sub} [^\circ K]$	4	10	15	20	25	30	35	40	45
Fsub	1,00	1,07	1,14	1,20	1,27	1,33	1,40	1,48	1,54

When subcooling ahead of the expansion valve is other than 4 °K , adjust the evaporator capacity by dividing by the appropriate correction factor found in Table 24B

**TABLE 25A: Refrigerant R449A - Capacities in kW**

Evaporating Temperature 10 °C										Evaporating Temperature 0 °C									
Orifice Type	Pressure drop across valve [bar]									Orifice Type	Pressure drop across valve [bar]								
	2	4	6	8	10	12	14	16	18		2	4	6	8	10	12	14	16	18
01	0,76	0,93	1,08	1,21	1,33	1,43	1,52	1,60	1,66	01	0,74	0,90	1,05	1,18	1,29	1,39	1,48	1,55	1,61
02	1,51	1,85	2,15	2,42	2,66	2,87	3,05	3,20	3,33	02	1,48	1,81	2,10	2,36	2,58	2,78	2,95	3,10	3,21
03	1,79	2,19	2,54	2,85	3,13	3,37	3,58	3,76	3,90	03	1,76	2,14	2,47	2,77	3,04	3,27	3,47	3,63	3,77
04	2,89	3,54	4,12	4,63	5,09	5,49	5,83	6,13	6,38	04	2,83	3,46	4,02	4,51	4,95	5,33	5,65	5,93	6,15
05	4,95	6,05	7,03	7,90	8,67	9,34	9,93	10,43	10,84	05	4,84	5,91	6,85	7,69	8,43	9,07	9,62	10,08	10,46
06	6,88	8,40	9,75	10,95	12,02	12,95	13,76	14,46	15,03	06	6,73	8,20	9,51	10,66	11,69	12,57	13,34	13,98	14,50
07	10,81	13,24	15,40	17,32	19,03	20,52	21,81	22,93	23,84	07	10,58	12,93	15,01	16,86	18,50	19,92	21,14	22,16	23,01
08	13,05	15,96	18,54	20,84	22,88	24,66	26,21	27,54	28,63	08	12,78	15,59	18,08	20,29	22,24	23,94	25,40	26,62	27,62
09	14,49	17,70	20,56	23,10	25,35	27,33	29,04	30,51	31,71	09	14,18	17,29	20,04	22,49	24,65	26,53	28,14	29,49	30,60
Evaporating Temperature -10 °C										Evaporating Temperature -20 °C									
Orifice Type	Pressure drop across valve [bar]									Orifice Type	Pressure drop across valve [bar]								
	2	4	6	8	10	12	14	16	18		2	4	6	8	10	12	14	16	18
01	0,77	0,93	1,07	1,20	1,31	1,41	1,49	1,56	1,62	01	0,78	0,94	1,08	1,21	1,32	1,41	1,49	1,55	1,61
02	1,53	1,86	2,15	2,40	2,63	2,82	2,99	3,13	3,24	02	1,57	1,89	2,17	2,42	2,63	2,82	2,98	3,11	3,22
03	1,82	2,20	2,53	2,83	3,09	3,31	3,51	3,67	3,80	03	1,86	2,23	2,56	2,84	3,09	3,31	3,50	3,65	3,77
04	2,93	3,56	4,11	4,60	5,03	5,40	5,72	5,99	6,21	04	3,00	3,61	4,15	4,62	5,04	5,40	5,70	5,96	6,16
05	5,02	6,08	7,01	7,84	8,56	9,19	9,73	10,19	10,55	05	5,14	6,17	7,08	7,88	8,58	9,19	9,70	10,13	10,48
06	6,97	8,43	9,73	10,87	11,88	12,75	13,49	14,12	14,63	06	7,13	8,57	9,83	10,93	11,90	12,74	13,45	14,04	14,53
07	10,95	13,30	15,36	17,19	18,80	20,19	21,38	22,40	23,20	07	11,21	13,50	15,52	17,29	18,84	20,18	21,32	22,27	23,04
08	13,23	16,03	18,50	20,68	22,60	24,27	25,69	26,90	27,86	08	13,54	16,28	18,68	20,80	22,65	24,25	25,61	26,75	27,67
09	14,69	17,78	20,51	22,93	25,05	26,89	28,46	29,80	30,86	09	15,03	18,06	20,72	23,06	25,10	26,87	28,37	29,63	30,65
Evaporating Temperature -30 °C										Evaporating Temperature -40 °C									
Orifice Type	Pressure drop across valve [bar]									Orifice Type	Pressure drop across valve [bar]								
	2	4	6	8	10	12	14	16	18		2	4	6	8	10	12	14	16	18
01	0,80	0,95	1,09	1,20	1,31	1,40	1,47	1,53	1,58	01	0,82	0,96	1,09	1,21	1,31	1,39	1,46	1,52	1,57
02	1,59	1,90	2,17	2,41	2,61	2,79	2,94	3,06	3,16	02	1,63	1,93	2,19	2,42	2,61	2,78	2,93	3,04	3,13
03	1,89	2,25	2,56	2,84	3,07	3,28	3,45	3,59	3,71	03	1,94	2,28	2,58	2,84	3,07	3,27	3,43	3,57	3,67
04	3,05	3,64	4,16	4,61	5,00	5,34	5,63	5,87	6,05	04	3,12	3,69	4,19	4,62	5,00	5,33	5,60	5,82	6,00
05	5,22	6,21	7,09	7,86	8,52	9,10	9,58	9,98	10,30	05	5,35	6,30	7,14	7,88	8,52	9,08	9,53	9,91	10,21
06	7,25	8,62	9,84	10,90	11,82	12,61	13,29	13,83	14,27	06	7,43	8,75	9,91	10,93	11,82	12,58	13,22	13,73	14,15
07	11,39	13,59	15,54	17,23	18,71	19,98	21,06	21,93	22,64	07	11,68	13,79	15,65	17,29	18,71	19,93	20,95	21,77	22,44
08	13,76	16,39	18,71	20,73	22,50	24,01	25,30	26,34	27,18	08	14,11	16,62	18,85	20,80	22,50	23,96	25,17	26,15	26,95
09	15,28	18,18	20,74	22,98	24,93	26,60	28,03	29,18	30,11	09	15,66	18,44	20,90	23,06	24,93	26,55	27,88	28,97	29,85

**TABLE: 25B - Correction factor for subcooling  $\Delta t_{sub} \neq 4^\circ K$**

$\Delta t_{sub} [^\circ K]$	4	10	15	20	25	30	35	40	45
Fsub	1,00	1,07	1,14	1,21	1,27	1,34	1,40	1,48	1,54

When subcooling ahead of the expansion valve is other than 4 °K , adjust the evaporator capacity by dividing by the appropriate correction factor found in Table 25B



**TABLE 26A: Refrigerant R450A - Capacities in kW**

Evaporating Temperature 10 °C										Evaporating Temperature 0 °C									
Orifice Type	Pressure drop across valve [bar]									Orifice Type	Pressure drop across valve [bar]								
	2	4	6	8	10	12	14	16	18		2	4	6	8	10	12	14	16	18
01	0,57	0,67	0,75	0,81	0,85	0,88	0,89	0,89	0,87	01	0,59	0,68	0,75	0,80	0,84	0,86	0,87	0,86	0,85
02	1,15	1,34	1,50	1,61	1,70	1,75	1,78	1,78	1,75	02	1,18	1,36	1,50	1,61	1,68	1,73	1,74	1,73	1,69
03	1,36	1,59	1,76	1,90	2,00	2,06	2,09	2,08	2,05	03	1,40	1,61	1,77	1,89	1,98	2,03	2,04	2,03	1,98
04	2,20	2,57	2,86	3,09	3,25	3,36	3,41	3,40	3,35	04	2,25	2,60	2,87	3,08	3,22	3,31	3,33	3,31	3,24
05	3,76	4,39	4,88	5,26	5,53	5,71	5,80	5,79	5,70	05	3,85	4,44	4,90	5,24	5,48	5,63	5,67	5,63	5,51
06	5,22	6,09	6,77	7,30	7,67	7,92	8,04	8,02	7,90	06	5,35	6,16	6,80	7,27	7,60	7,80	7,86	7,81	7,64
07	8,21	9,60	10,70	11,54	12,15	12,54	12,74	12,72	12,53	07	8,41	9,71	10,74	11,50	12,03	12,36	12,46	12,38	12,12
08	9,92	11,57	12,88	13,89	14,60	15,08	15,30	15,27	15,04	08	10,16	11,71	12,93	13,84	14,47	14,85	14,97	14,87	14,55
09	11,01	12,84	14,28	15,40	16,19	16,71	16,95	16,92	16,66	09	11,27	12,98	14,33	15,34	16,03	16,46	16,59	16,47	16,12
Evaporating Temperature -10 °C										Evaporating Temperature -20 °C									
Orifice Type	Pressure drop across valve [bar]									Orifice Type	Pressure drop across valve [bar]								
	2	4	6	8	10	12	14	16	18		2	4	6	8	10	12	14	16	18
01	0,60	0,68	0,74	0,79	0,82	0,84	0,84	0,83	0,80	01	0,60	0,67	0,73	0,77	0,80	0,81	0,80	0,78	0,75
02	1,19	1,36	1,48	1,58	1,64	1,67	1,68	1,65	1,60	02	1,20	1,35	1,46	1,54	1,59	1,61	1,60	1,57	1,50
03	1,41	1,60	1,75	1,86	1,93	1,97	1,97	1,94	1,88	03	1,42	1,59	1,72	1,82	1,87	1,89	1,88	1,84	1,76
04	2,28	2,59	2,84	3,02	3,14	3,21	3,21	3,17	3,07	04	2,29	2,58	2,80	2,95	3,05	3,09	3,07	3,00	2,88
05	3,90	4,43	4,85	5,15	5,35	5,46	5,47	5,39	5,23	05	3,92	4,40	4,77	5,03	5,19	5,26	5,22	5,11	4,90
06	5,42	6,15	6,73	7,15	7,42	7,57	7,58	7,47	7,25	06	5,45	6,11	6,62	6,98	7,20	7,29	7,24	7,08	6,79
07	8,51	9,70	10,63	11,30	11,74	11,99	12,01	11,85	11,49	07	8,56	9,63	10,46	11,04	11,39	11,54	11,47	11,22	10,77
08	10,28	11,70	12,79	13,60	14,12	14,40	14,43	14,23	13,80	08	10,34	11,62	12,60	13,29	13,70	13,87	13,78	13,48	12,93
09	11,41	12,97	14,19	15,08	15,65	15,96	15,99	15,76	15,29	09	11,48	12,89	13,97	14,73	15,18	15,37	15,27	14,93	14,33
Evaporating Temperature -30 °C										Evaporating Temperature -40 °C									
Orifice Type	Pressure drop across valve [bar]									Orifice Type	Pressure drop across valve [bar]								
	2	4	6	8	10	12	14	16	18		2	4	6	8	10	12	14	16	18
01	0,60	0,66	0,71	0,74	0,76	0,76	0,75	0,73	0,69	01	0,61	0,66	0,70	0,73	0,74	0,74	0,73	0,70	0,66
02	1,20	1,33	1,42	1,49	1,52	1,53	1,51	1,46	1,38	02	1,21	1,32	1,41	1,46	1,49	1,49	1,45	1,40	1,31
03	1,42	1,57	1,68	1,75	1,79	1,80	1,77	1,71	1,62	03	1,44	1,56	1,66	1,72	1,75	1,75	1,71	1,64	1,54
04	2,29	2,54	2,72	2,85	2,92	2,93	2,88	2,79	2,64	04	2,31	2,53	2,70	2,80	2,85	2,85	2,78	2,67	2,51
05	3,92	4,34	4,65	4,86	4,97	4,98	4,91	4,74	4,49	05	3,96	4,32	4,60	4,78	4,86	4,84	4,74	4,55	4,27
06	5,45	6,02	6,45	6,74	6,89	6,91	6,80	6,57	6,23	06	5,51	6,00	6,39	6,63	6,73	6,72	6,57	6,31	5,92
07	8,56	9,49	10,19	10,65	10,90	10,94	10,78	10,43	9,88	07	8,65	9,46	10,09	10,48	10,66	10,64	10,41	10,00	9,39
08	10,34	11,44	12,27	12,82	13,10	13,15	12,95	12,52	11,86	08	10,45	11,40	12,14	12,61	12,82	12,79	12,51	12,01	11,27
09	11,47	12,69	13,60	14,21	14,52	14,57	14,35	13,87	13,14	09	11,60	12,65	13,47	13,97	14,20	14,17	13,86	13,30	12,49

**TABLE 26B - Correction factors for subcooling  $\Delta t_{sub} \neq 4^\circ K$**

$\Delta t_{sub} [^\circ K]$	4	10	15	20	25	30	35	40	45
Fsub	1,00	1,06	1,12	1,18	1,24	1,30	1,36	1,40	1,45

When subcooling ahead of the expansion valve is other than 4 °K , adjust the evaporator capacity by dividing by the appropriate correction factor found in Table 26B

**TABLE 27A: Refrigerant R452A - Capacities in kW**

Evaporating Temperature 10 °C										Evaporating Temperature 0 °C									
Orifice Type	Pressure drop across valve [bar]									Orifice Type	Pressure drop across valve [bar]								
	2	4	6	8	10	12	14	16	18		2	4	6	8	10	12	14	16	18
01	0,57	0,69	0,80	0,89	0,97	1,03	1,08	1,12	1,14	01	0,60	0,72	0,83	0,92	1,00	1,06	1,11	1,15	1,17
02	1,14	1,38	1,60	1,78	1,93	2,06	2,16	2,23	2,28	02	1,19	1,44	1,66	1,84	1,99	2,12	2,22	2,29	2,34
03	1,35	1,64	1,88	2,10	2,27	2,42	2,54	2,62	2,67	03	1,41	1,70	1,95	2,17	2,35	2,49	2,61	2,69	2,75
04	2,17	2,65	3,06	3,41	3,70	3,94	4,14	4,28	4,37	04	2,28	2,76	3,17	3,52	3,82	4,06	4,25	4,39	4,49
05	3,72	4,52	5,21	5,81	6,31	6,72	7,04	7,27	7,42	05	3,90	4,71	5,41	6,00	6,50	6,91	7,23	7,47	7,63
06	5,17	6,28	7,23	8,06	8,75	9,31	9,76	10,08	10,29	06	5,42	6,54	7,51	8,32	9,02	9,58	10,03	10,36	10,57
07	8,12	9,90	11,42	12,74	13,85	14,75	15,46	15,98	16,32	07	8,51	10,30	11,85	13,16	14,28	15,18	15,90	16,43	16,77
08	9,81	11,93	13,75	15,33	16,65	17,73	18,58	19,20	19,60	08	10,28	12,42	14,27	15,84	17,16	18,24	19,10	19,73	20,14
09	10,89	13,23	15,25	16,99	18,45	19,64	20,58	21,27	21,71	09	11,41	13,78	15,83	17,56	19,02	20,21	21,16	21,86	22,31
Evaporating Temperature -10 °C										Evaporating Temperature -20 °C									
Orifice Type	Pressure drop across valve [bar]									Orifice Type	Pressure drop across valve [bar]								
	2	4	6	8	10	12	14	16	18		2	4	6	8	10	12	14	16	18
01	0,62	0,74	0,85	0,94	1,01	1,07	1,12	1,16	1,18	01	0,63	0,75	0,86	0,94	1,01	1,07	1,12	1,15	1,17
02	1,23	1,48	1,69	1,87	2,03	2,15	2,24	2,31	2,36	02	1,27	1,51	1,71	1,89	2,03	2,14	2,23	2,29	2,33
03	1,47	1,75	2,00	2,21	2,38	2,52	2,63	2,72	2,76	03	1,51	1,78	2,02	2,22	2,38	2,52	2,62	2,69	2,73
04	2,36	2,83	3,24	3,59	3,88	4,11	4,29	4,43	4,51	04	2,43	2,89	3,28	3,61	3,88	4,11	4,27	4,39	4,46
05	4,04	4,84	5,53	6,12	6,61	7,00	7,31	7,54	7,67	05	4,15	4,93	5,60	6,16	6,61	6,99	7,27	7,47	7,59
06	5,62	6,72	7,68	8,48	9,16	9,70	10,13	10,45	10,63	06	5,77	6,85	7,77	8,54	9,17	9,69	10,08	10,36	10,52
07	8,83	10,59	12,13	13,42	14,50	15,37	16,06	16,57	16,87	07	9,07	10,80	12,27	13,50	14,52	15,35	15,98	16,43	16,69
08	10,66	12,77	14,60	16,14	17,44	18,47	19,29	19,90	20,26	08	10,95	13,02	14,77	16,24	17,45	18,45	19,19	19,73	20,05
09	11,84	14,17	16,19	17,89	19,33	20,46	21,37	22,05	22,44	09	12,16	14,44	16,38	18,01	19,34	20,44	21,26	21,86	22,20
Evaporating Temperature -30 °C										Evaporating Temperature -40 °C									
Orifice Type	Pressure drop across valve [bar]									Orifice Type	Pressure drop across valve [bar]								
	2	4	6	8	10	12	14	16	18		2	4	6	8	10	12	14	16	18
01	0,64	0,76	0,85	0,94	1,00	1,05	1,09	1,12	1,13	01	0,65	0,76	0,85	0,93	0,99	1,03	1,07	1,09	1,10
02	1,29	1,52	1,71	1,87	2,00	2,11	2,19	2,24	2,27	02	1,31	1,52	1,70	1,85	1,97	2,07	2,14	2,18	2,20
03	1,53	1,80	2,02	2,20	2,36	2,48	2,57	2,63	2,66	03	1,56	1,80	2,01	2,18	2,32	2,43	2,51	2,56	2,58
04	2,46	2,91	3,27	3,58	3,84	4,04	4,19	4,29	4,35	04	2,50	2,91	3,26	3,55	3,78	3,96	4,09	4,18	4,21
05	4,22	4,97	5,58	6,11	6,54	6,87	7,12	7,30	7,39	05	4,29	4,98	5,56	6,05	6,44	6,74	6,96	7,10	7,16
06	5,86	6,89	7,74	8,47	9,07	9,53	9,88	10,11	10,24	06	5,96	6,91	7,72	8,39	8,93	9,35	9,65	9,84	9,92
07	9,20	10,86	12,23	13,39	14,35	15,09	15,66	16,04	16,25	07	9,36	10,89	12,19	13,27	14,14	14,81	15,30	15,61	15,74
08	11,12	13,10	14,73	16,11	17,26	18,14	18,81	19,26	19,51	08	11,31	13,13	14,68	15,97	17,00	17,80	18,38	18,75	18,90
09	12,34	14,53	16,33	17,86	19,12	20,10	20,84	21,34	21,61	09	12,56	14,57	16,28	17,70	18,84	19,72	20,37	20,77	20,94

**TABLE: 27B - Correction factor for subcooling  $\Delta t_{sub} \neq 4^\circ K$**

$\Delta t_{sub} [^\circ K]$	4	10	15	20	25	30	35	40	45
$F_{sub}$	1,00	1,14	1,15	1,23	1,30	1,37	1,45	1,49	1,56

When subcooling ahead of the expansion valve is other than 4 °K , adjust the evaporator capacity by dividing by the appropriate correction factor found in Table 25B

[www.castel.it](http://www.castel.it)



ed. 001-VE-ENG

Castel can accept no responsibility for any errors or changes in the catalogues, handbooks, brochures and other printed material. Castel reserves the right to make changes and improvements to its products without notice. All trademarks mentioned are the property of their respective owners.

The name and Castel logotype are registered trademarks of Castel Srl.  
All rights reserved.

Castel Srl - Via Provinciale 2-4 - 20060 Pessano con Bornago - MI